



Glide

Solutions Document



3form Glide is a lightweight partition and screen system that allows you to control light, add privacy and divide space. Made specifically for lightweight 3form Varia Ecoresin, a cost-effective solution for most sliding partition applications.

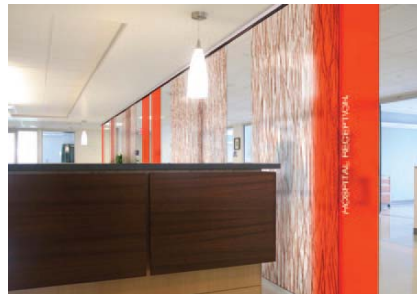

SOLUTIONS OVERVIEW

The Glide system is designed to be used with 3.1 mm gauge Varia Ecoresin material up to 3 m² in size. The system can be installed with one continuous track (partition or screen) or multiple tracks for bypassing panels (partition)

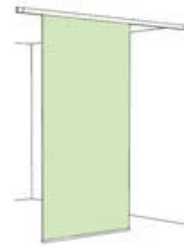
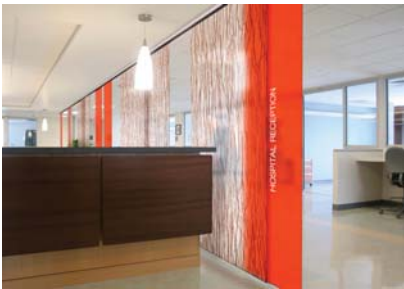

CEILING MOUNTED PARTITION



CEILING MOUNTED SCREEN

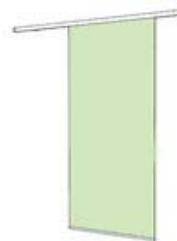

WALL MOUNTED SCREEN

PARTS OVERVIEW

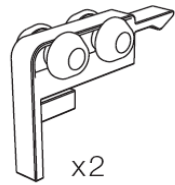

x2

Panel kit
3-15-0055-K



x2

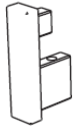

x2

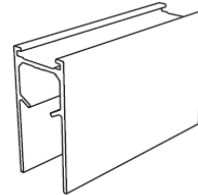
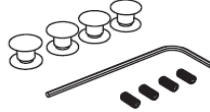

Top Track
3-15-0051

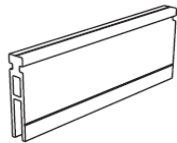

Panel Top Rail
0-15-1772

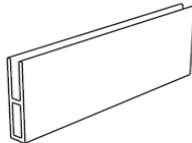

Panel Bottom Rail
0-15-1773

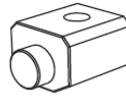

Bumper
3-15-2779

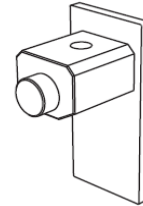

End Cap (+bumper)
3-15-2780

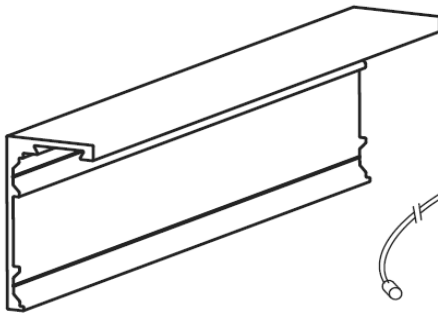

Wall Mount Bracket
3-15-2776

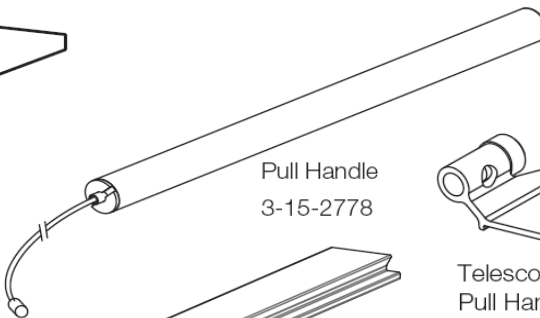

Pull Handle
3-15-2778

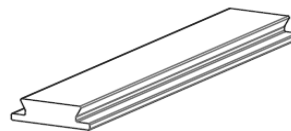

Wall Bracket / Extrusion
Joiner
3-15-2777

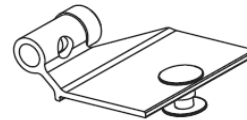

Telescoping Catch Left /
Pull Handle Mount
3-15-2781

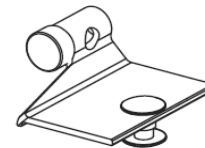

Telescoping Catch Right /
Pull Handle Mount
3-15-2782

OVERALL DIMENSIONS

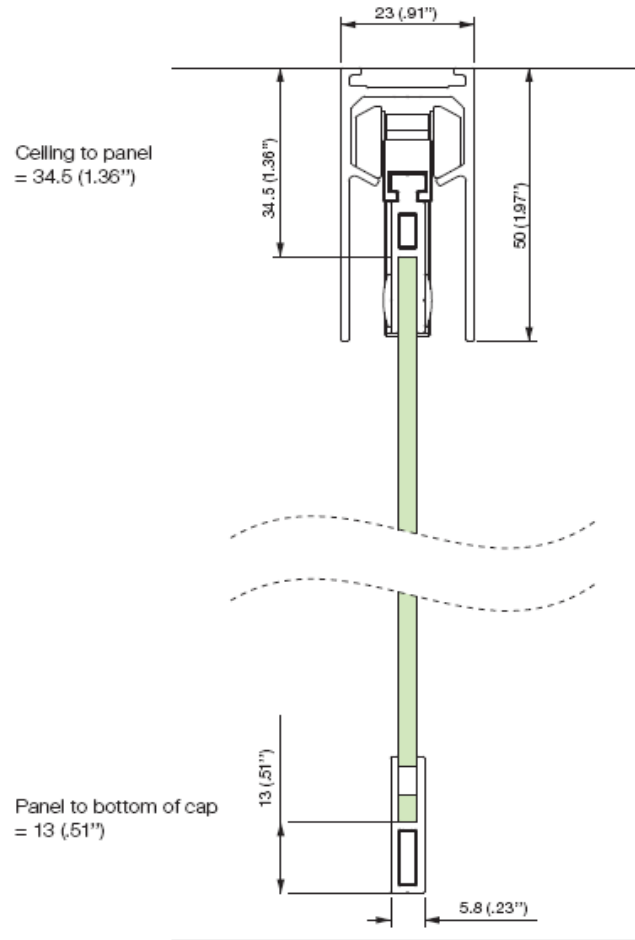

SOLUTION - CEILING MOUNTED PARTITION

This is a simple Glide installation with one track and one sliding panel. Ideal for corporate environments requiring varying levels of privacy.

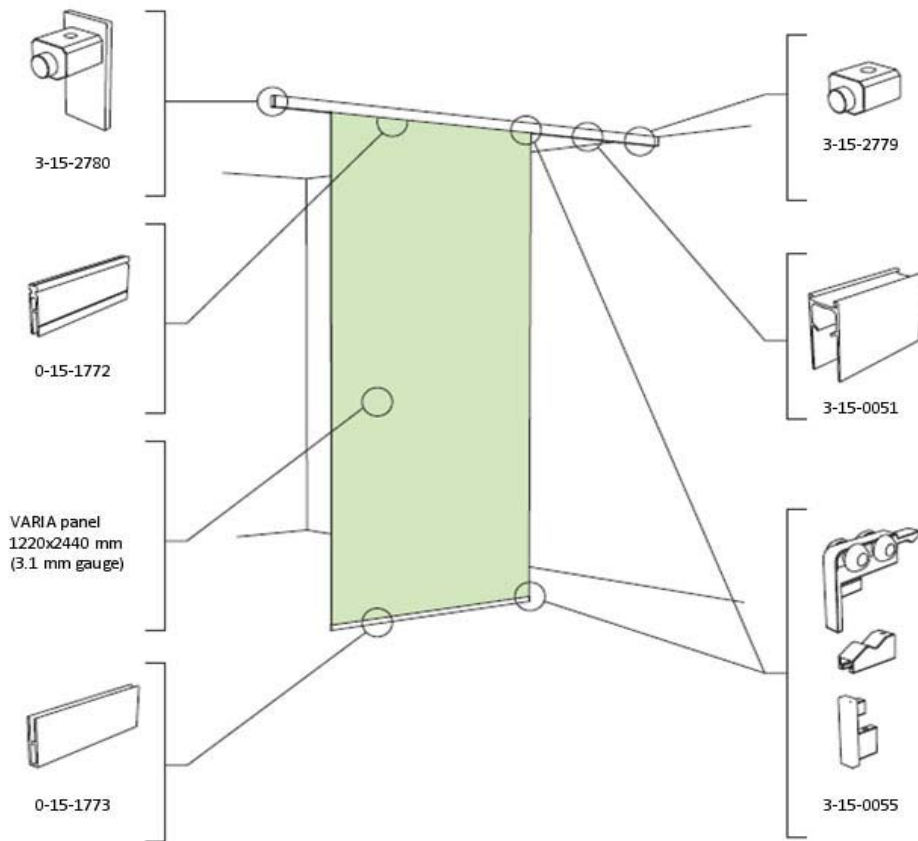

SOLUTION - CEILING MOUNTED SCREEN

Multiple tracks can be ceiling mounted adjacent to each other for bypassing screens. This allows multiple panels to form a wide screen but enables the panels to be moved off to the sides to create an opening.

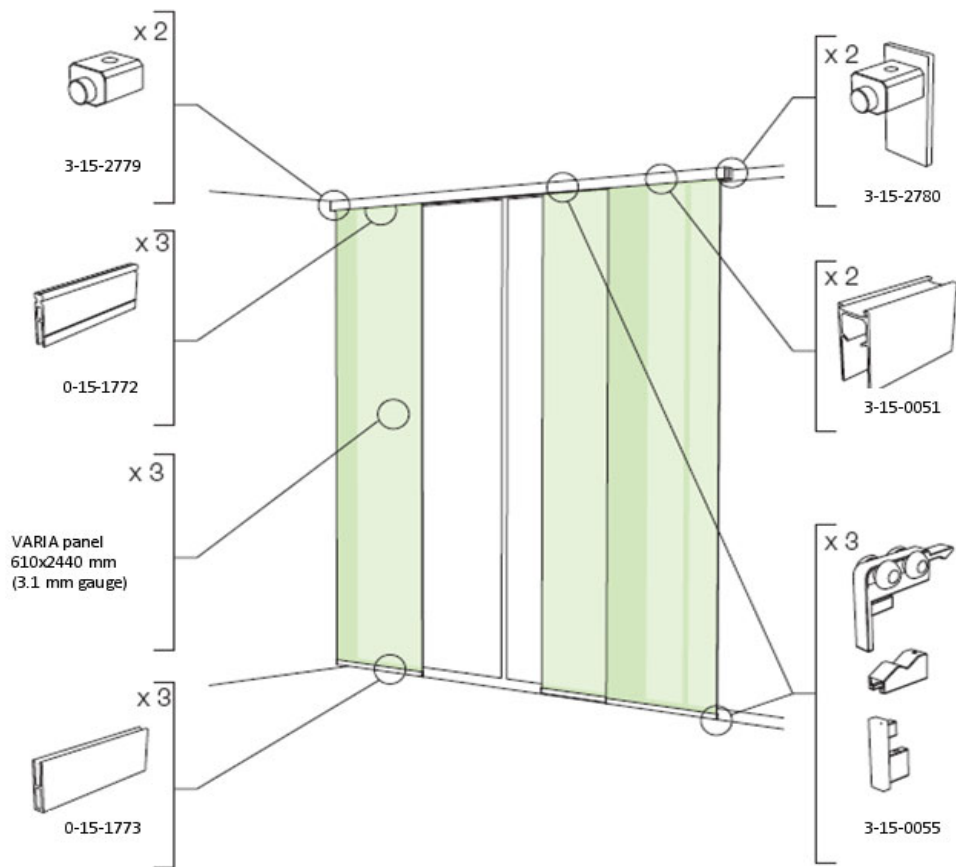

SOLUTION - WALL MOUNTED SCREEN

This configuration can be used as a screen in a space or as a covering for an opening or window, much like a curtain. The length of the track can be extended by connecting multiple extrusions together, and multiple panels can be mounted to the same track if a larger screen is desired.

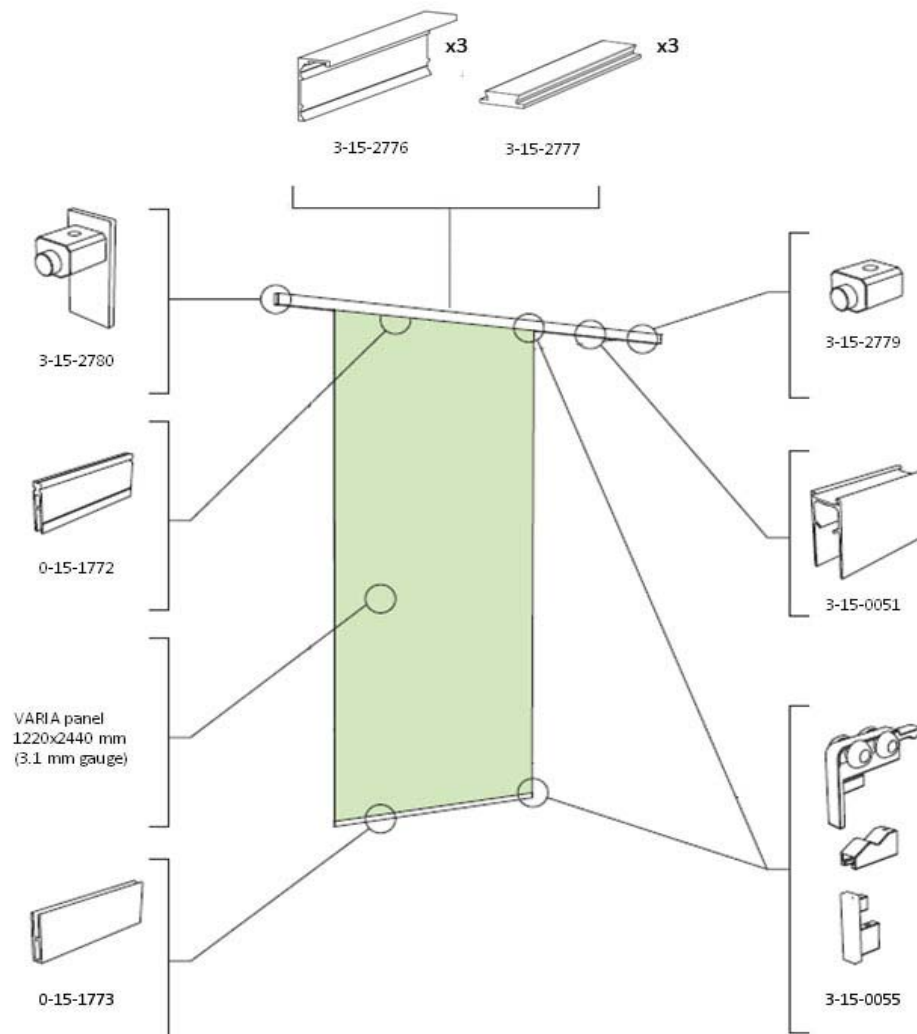

SOLUTION - TELESCOPING CATCH / PULL HANDLE

The Telescoping catch is useful for multiple panel conditions or to mount the Pull Handle. Order (1) for the leading and trailing panel (unless used with the pull handle) and (2) for intermediate panels.

