

3form

DITTO™

Installation Manual

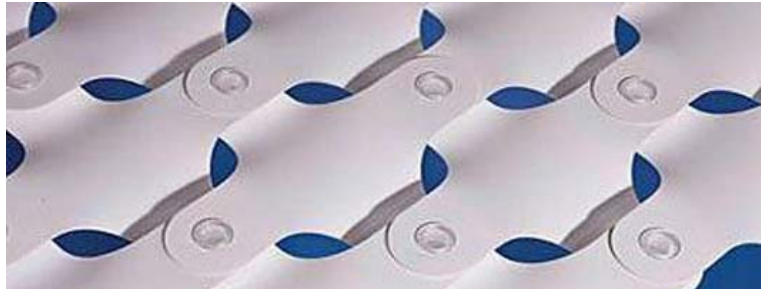

TILES ASSEMBLY

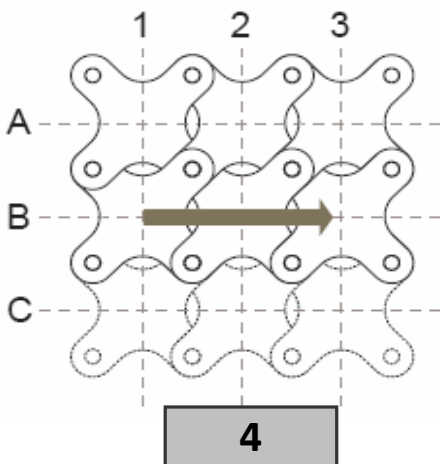
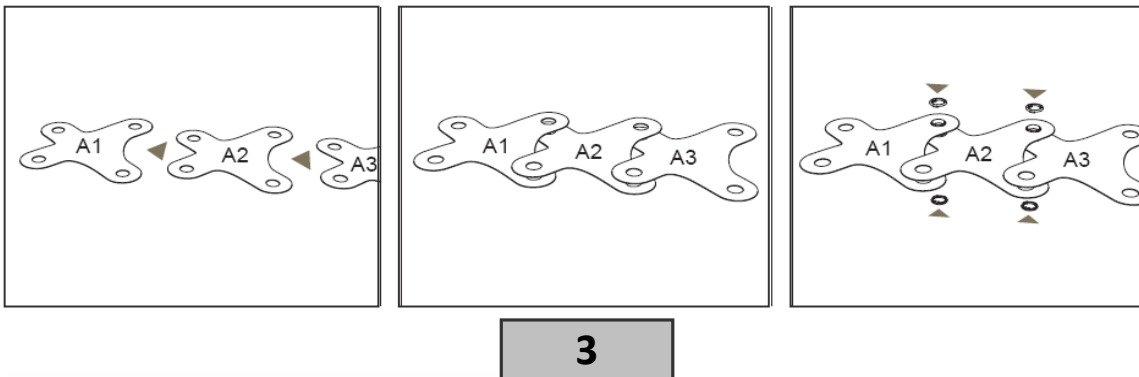
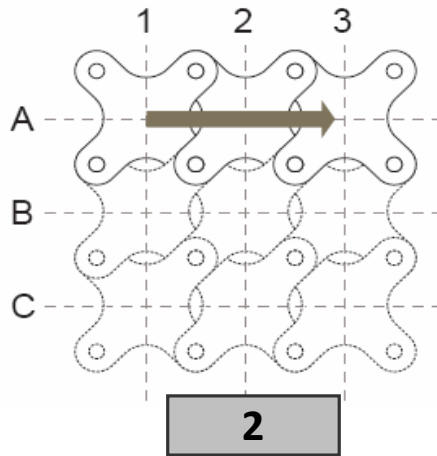
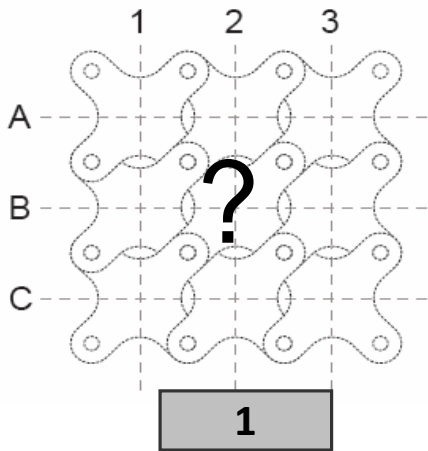

TILES ASSEMBLY

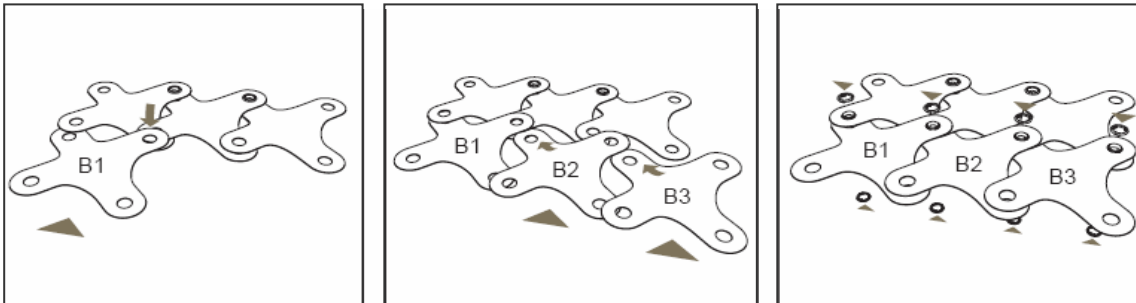

5

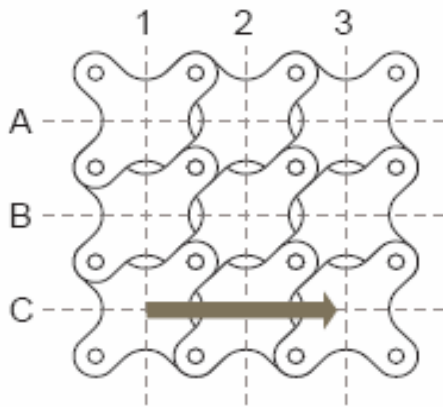

6

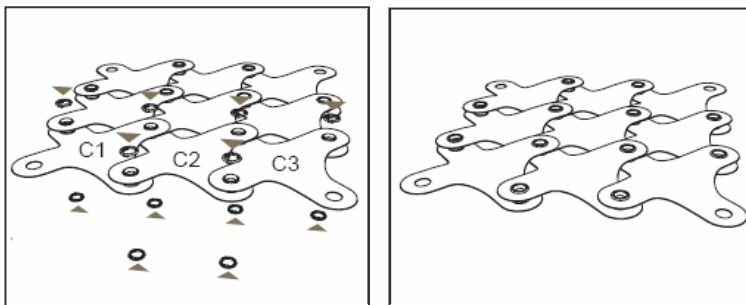

7

(DIS)CONNECT

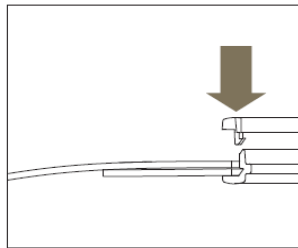
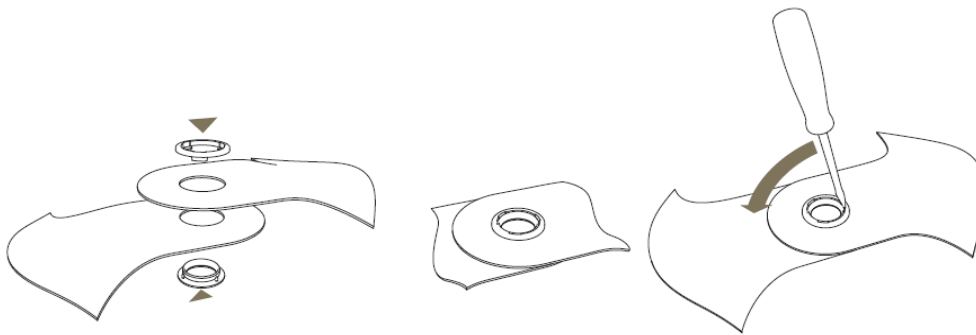
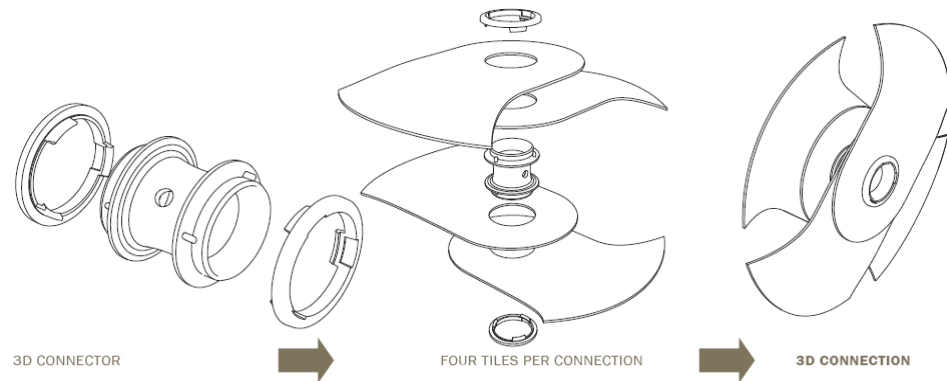

INSTALL

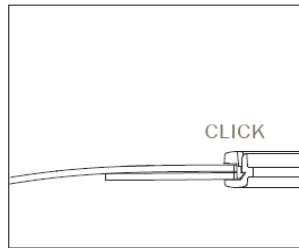

CLICK

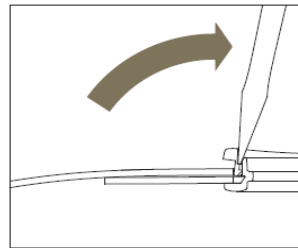

REMOVE

INSTALLATION POINT SUPPORT - WALL (TO CEILING) MOUNTED



Ditto tiles



3D connectors
D-10-2001

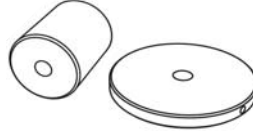

see Point Support
hardware



Ditto
washer
D-10-2004



countersunk
screw
D-10-2008

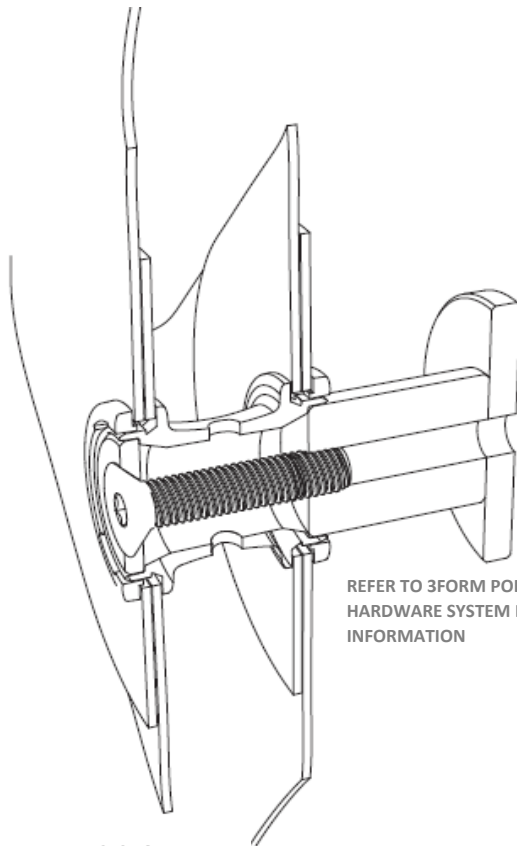

SECTION
3D CONNECTION

REFER TO 3FORM POINT SUPPORT
HARDWARE SYSTEM FOR ADDITIONAL
INFORMATION

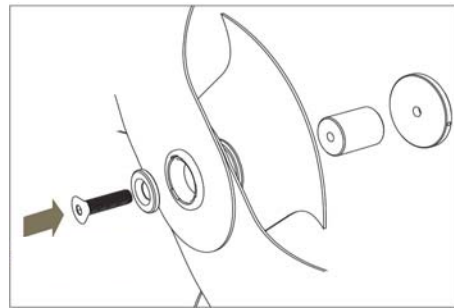

INSTALLATION SUSPEND - PARTITION APPLICATION



Ditto tiles



3D connectors
D-10-2001

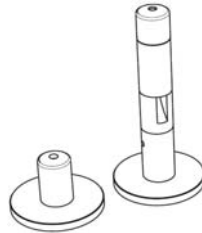

see Suspend
hardware



connector for
Ditto spacer
D-10-2004

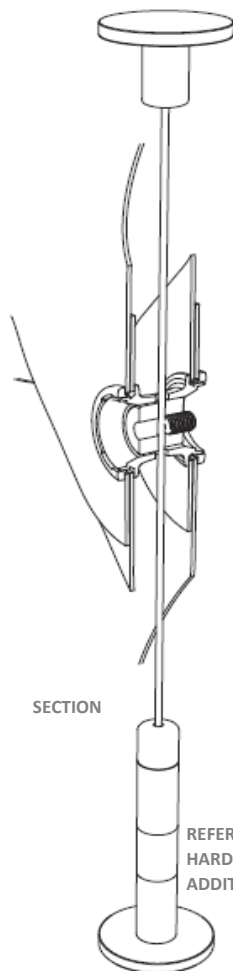

SECTION

REFER TO 3FORM SUSPEND
HARDWARE SYSTEM FOR
ADDITIONAL INFORMATION

